

## Industrial LED UFO High Bay - 200W - CCT - With motion sensor - 170lm/W - LIFUD Driver - IP65 - 5 years warranty

Ref. K8155-200W-SENSOR

UFO LED Industrial Pendant Light 200W high efficiency: 170lm/W and Lifud Driver. It stands out for its robust design, high quality, and versatility. It features a high-sensitivity microwave motion sensor with advanced functions and a power regulation switch. Incorporates CCT system for adjusting color temperature between warm white (3000K), neutral white (4000K), and cool white (5000K). \*\*5-Year Warranty\*\*



### Product data

|                         |                  |
|-------------------------|------------------|
| High                    | 187mm            |
| Width                   | Ø12.2in          |
| Beam angle (°)          | 90 degrees       |
| Certs                   | CE, ROHS         |
| Energy efficiency class | B                |
| CRI                     | 70-80            |
| Dimmable                | Yes              |
| Driver                  | Internal, Lifud  |
| Efficiency (Lm/w)       | 170              |
| Warranty                | 5 years          |
| IK                      | 09               |
| IP                      | IP65             |
| Kelvin (K)              | 3000, 4000, 5000 |
| Lumens (Lm)             | 34000            |
| Material                | Aluminum         |
| Material diffuser       | Polycarbonate    |
| Assembly                | Suspension       |
| Orientable              | Yes              |
| Power (W)               | 200, 130, 170    |
| Sensor                  | Yes              |
| Nominal Voltage (V)     | 220 - 240 V AC   |
| Type of LED             | SMD 2835         |

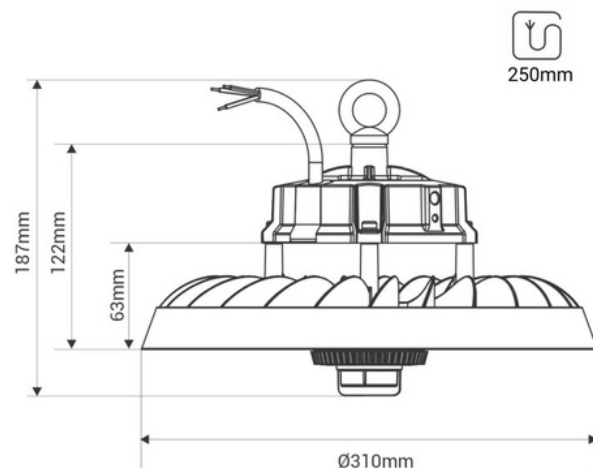

|                 |   |
|-----------------|---|
| Type of sensor  | Microwave   |
| Key             | CCT   |
| Outdoor Use     | Yes   |
| Recommended Use | Industry, Parking, Industrial Warehouses, Sports Fields |

### Product variants

*Reference*

*Attributes*

K8155-200W-SENSOR

